

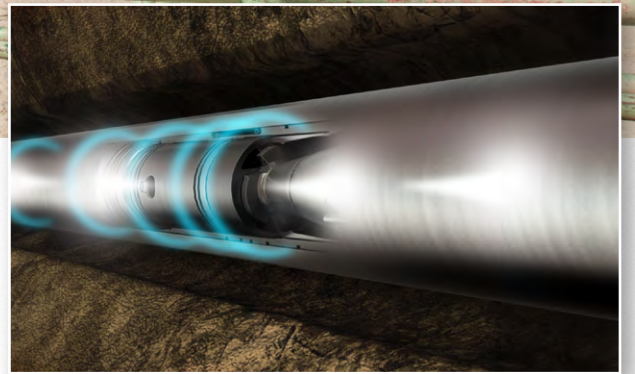

DigiScope

Slimhole measurements
while drilling



DigiScope Slimhole Measurements While Drilling

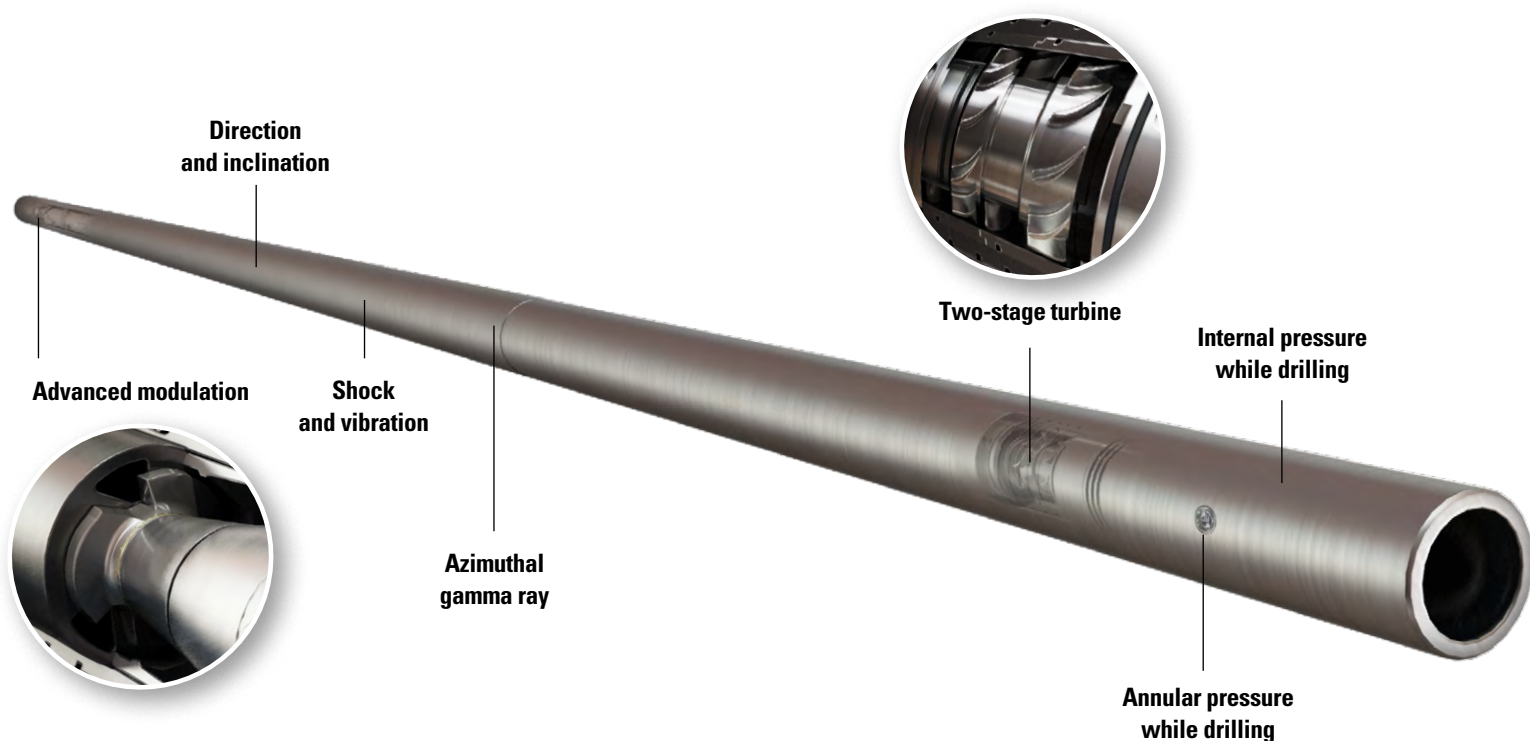

The DigiScope* slimhole measurement-while-drilling service transmits high-quality data to surface for real-time reservoir description and geosteering in land, extended-reach and deepwater wells. This high-speed telemetry service powers the most extensive suite of LWD services and generates a strong signal in the deepest wells.

Telemetry service for comprehensive slimhole LWD suites

DigiScope service transmits high-resolution reservoir characterization data at high bit rates while minimizing ROP restriction. The quality of the signal is maintained by an unparalleled range of frequencies available from 0.25–24 Hz at physical transmission rates up to 36 bps. Fully compatible with the Orion II* data compression platform, the DigiScope physical bit rate is further increased to greater than 140 bps. The quality and the strength of the signal combine to deliver high-quality data at faster rates.

This slimhole MWD service acquires and transmits wellbore surveys, azimuthal gamma ray, annular and internal pressure, and shock and vibration data while drilling.

Power for complex BHAs in any configuration

The DigiScope turbine assembly includes two propellers and a high-density alternator for high power. In addition to its own consumption, the DigiScope service provides up to 110 W uphole and 110 W downhole for flexibility in BHA configuration. Power generation is possible at a wide range of mud flow rates, and a system of high-efficiency conversion electronics ensures the power is used to its full potential.

Communication with proven modulation algorithm

The DigiScope service uses a special modulation algorithm called smooth phase shift keying (SPSK)—applied to MWD for the first time. Using this method the modulator maintains high resolution and delivers a large number of data points at high ROP. The DigiScope tool contains advanced modulation electronics to support SPSK, which eliminates the modulator rotor's stops and starts, increasing the reliability of already proven Schlumberger MWD electronics.



DigiScope service acquires real-time measurements for drilling optimization and formation evaluation.

DigiScope

Slimhole measurements while drilling

APPLICATIONS

- Slimhole land, extended-reach, and deepwater wells
- Well placement
- Transmission of multiple real-time measurements during high-speed drilling
- Drilling optimization and wellbore surveying

BENEFITS

- Power for complete petrophysical LWD logging suites
- Strong signal at high data rate to enable fast drilling
- Fast downlinking while logging for increased operational efficiency
- High data quality for real-time decision making
- Pumps-off pressure data for formation integrity test (FIT) and leakoff test (LOT) analyses

FEATURES

- Advanced modulator electronics for smooth phase shift keying (SPSK) telemetry and Orion II* data compression platform
- Smart tool diagnostics for reliability-centered decisions
- Flexible BHA tool configurations
- Continuous direction and inclination (D&I) plus toolface and azimuthal quadrant gamma ray
- Annular and internal pressure while drilling
- Shock and vibration
- Combinability with all slimhole Schlumberger LWD services

The DigiScope* slimhole measurement-while-drilling service transmits high-quality data to surface for real-time reservoir description and geosteering in land, extended-reach, and deepwater wells. This high-speed telemetry service powers the most extensive suite of LWD services and generates a strong signal in the deepest wells.

The DigiScope two-stage turbine powers complex LWD technologies above and below the tool simultaneously for flexible BHA configuration. With multiple services acquiring measurements while drilling, the SPSK modulation algorithm applied by DigiScope advanced electronics transmits dense, high-resolution data to surface at high ROP.

Wellbore survey data to assist in geosteering decisions

The DigiScope service captures traditional survey data such as real-time direction, inclination, and toolface. The service provides azimuthal gamma ray images, in addition to LWD measurements, to give operators critical information for geosteering extended-reach wells with the assurance of actual well trajectory throughout drilling operations.

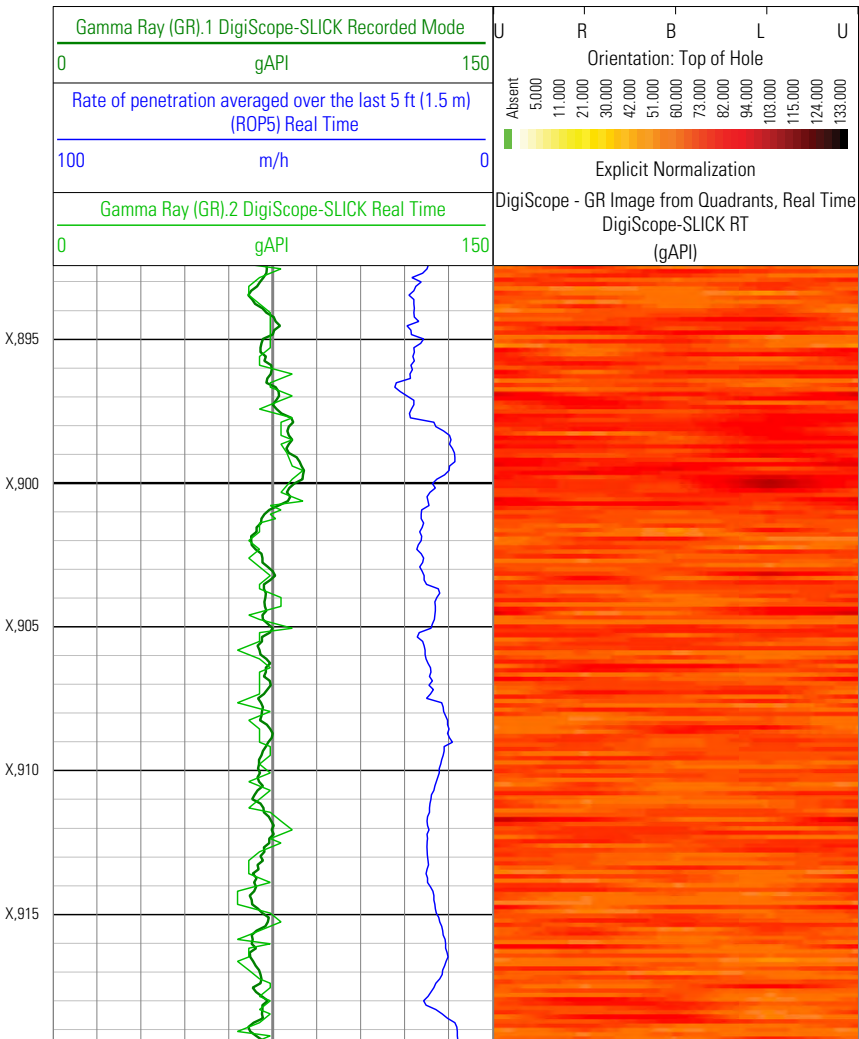

The DigiScope signal maintains strength and data quality to deliver real-time data comparable to recorded mode.

Real-time annular and internal pressure for drilling optimization

The measurement of annular and internal pressure while drilling enables drilling optimization through mud-weight monitoring. DigiScope service also collects pumps-off pressure and equivalent static density (ESD) data for FIT and LOT, which are crucial to evaluating wellbore stability. Pumps-off connection data help to interpret complex drilling geomechanics such as pore pressure, fracture gradient, and wellbore stability. Optimization of drilling parameters for these issues reduces risk and helps improve ROP.

Drilling mechanics measurements to mitigate risk

With real-time shock and vibration data delivered to surface, engineers have an advantage in adjusting drilling parameters for better performance and risk mitigation. These adjustments help preserve the life expectancy of BHA components and contribute to a higher quality wellbore. The DigiScope service measures lateral and axial shocks.

Mechanical Specifications

Operating frequencies, Hz	0.25 to 24		
Physical bit rate, bps	0.25 to 36		
Effective bit rate, bps	>140 with Orion II data compression		
Power supply	Dual-stage turbine power		
Combinability	All 4.75-in Schlumberger LWD tools		
Telemetry type	Continuous wave		
Downhole memory capacity	96 MB		
Recording time	300 h at low recording rate		
Tool nominal OD, in [mm]	4.75 [120.65]		
Tool max. OD, in [mm]	5.05 [128.27]		
Tool length, ft [m]	ROP version	I/APWD version	Slick version
	28.9 [8.80]	29.9 [9.10]	28.9 [8.80]
Hole size, in	5¼ to 6¼		
Weight, lbm [kg]	880 [400]		
Operating temperature, degF [degC]	300 [150]		
Max. dogleg severity			
Rotary mode, °/100 ft	15		
Sliding mode, °/100 ft	30		
Max. shock	30 min at Shock Level 3 (>10 Hz above 50 g_n), 200,000 cumulative shocks above 50 g_n)		
Max. external pressure			
Standard service, psi [MPa]	25,000 [172]		
High-pressure option, psi [MPa]	30,000 [207]		
Flow range, galUS/min [L/min]	150 to 400 [567.8 to 1,514]		

Measurement Specifications

Direction and Inclination Survey	Stationary	Continuous
Inclination		
Range, °	0 to 180	0 to 180
Accuracy, °	±0.1 (1 σ)	±0.2 (1 σ)
Resolution, °	0.03	0.1
Azimuth		
Range, °	0 to 360	0 to 360
Accuracy, °	±1 (1 σ) above 5° inclination	±2 (1 σ)
Resolution, °	0.5	1
Toolface		
Min. update period, s	3	
Range, °	0 to 360	
Accuracy, °	±2 (1 σ)	
Programmable magnetic to gravity toolface switching, °	5 to 8 (regular) or 2.5 to 3.5 (low)	
Gamma Ray (Average and Quadrant Measurement)		
Range, gAPI	0–1,000	0–1,000
Accuracy, %	±5	±5
Statistical repeatability	±3 gAPI at 100 gAPI and 100 ft/h, 3-point average	±3 gAPI at 100 gAPI and 100 ft/h, 3-point average
Vertical resolution, in	12	12
Distance from bottom of tool, ft [m]	6.8 [2.1]	6.8 [2.1]
Annular Pressure Measurement		
Range, psi [kPa]	0–30,000 [0–206,843]	
Accuracy, psi [kPa]	15 [103]	
Resolution, psi [kPa]	1.5 [10.3]	
Internal Pressure Measurement		
Range, psi [kPa]	0–32,000 [0–220,632]	
Accuracy, psi [kPa]	15 [103]	
Resolution, psi [kPa]	1.5 [10.3]	
Drilling Mechanics Measurement		
Vibration (x, y, z)		
Range, g_n	0–60 (lateral), 0–32 (axial)	
Accuracy, g_n	±1	
Resolution, g_n	0.125 (lateral), 0.25 (axial)	
Shock		
Range, g_n	±500	
Accuracy, g_n	±10%	
Resolution, g_n	10	
Collar rotation		
Range, rpm	0–255	
Accuracy, rpm	±10	
Resolution, rpm	1	



Find out more about DigiScope slimhole MWD service at slb.com/DigiScope

Animation

Watch an animation that shows DigiScope service produce more power and deliver more data faster.

Case Study

Read about how the DigiScope slimhole MWD service has been used in China to break the Schlumberger record for physical transmission rate in a 6-in hole with 9 bps while drilling and 18 bps while underreaming.

Product Sheet

Find out more about DigiScope measurements and get the full list of mechanical and measurement specifications.

Complete slimhole systems

PowerDrive Archer

High build rate RSS
slb.com/PowerDriveArcher

PowerDrive X6

Rotary steerable system
slb.com/PowerDriveX6

MicroScope

Resistivity and imaging while drilling
slb.com/MicroScope

PeriScope

Bed boundary mapper
slb.com/PeriScope

SonicScope

Multipole sonic while drilling
slb.com/SonicScope

StethoScope

Formation pressure while drilling
slb.com/StethoScope

adnVISION

Azimuthal density neutron
slb.com/adnVISION

i-DRILL

Engineered drilling system design
slb.com/iDRILL

www.slb.com/DigiScope

Schlumberger