

# D-SANDER



## FEATURES

- Designed for high-volume, continuous removal of sand and abrasive cuttings
- Available in two configurations
- Processes 500 to 1,500 GPM (1,892.7 to 5,678.1 L/min)
- Minimizes sand-related problems
- Configures to customer needs
- Up to three times the normal service life of conventional rubber-lined, metal units
- Rugged construction

## BENEFITS

- Removes 95% of drilled solids to 74 microns and 50% to 40 microns
- Easy to use
- Field-proven design
- Minimizes maintenance, repair and replacement of downstream equipment
- Minimizes downtime
- Increases bit performance by 20%
- Reduces overall drilling time by 23%

The M-I SWACO D-SANDER\* hydrocyclone is designed for high-volume, continuous removal of sand and abrasive cuttings from drilling fluids.

The 12-in. (304.8-mm) D-SANDER hydrocyclone, the first used in the industry, reduces sand content to a trace in normal drilling fluids. The D-SANDER unit is a basic piece of rig equipment that also helps limit repair and replacement of pump parts damaged by abrasiveladen drilling fluids. It is available in two configurations — slant-mount and space-saving vertical-mount — with single, dual or triple long-lasting compounded polyurethane clones.

## Features

**Efficient.** The 12-in. (304.8-mm) D-SANDER hydrocyclone removes 95% of drilled solids to 74 microns and 50% to 40 microns.

**High processing rates.** Processing capacities range from 500 GPM (1,892.7 L/min) with the 12-in. (304.8-mm) single clone to 1,500 GPM (5,678.1 L/min) with three 12-in. (304.8-mm) clones.

**Customer-specific configurations.** The M-I SWACO D-SANDER unit is available with space-saving vertical-mount skids or slant-mount skids featuring single, dual or triple clones.

**Easy-to-use, field-proven design.** Field-proven in years of oilfield operation, each hydrocyclone assembly includes four replaceable wear-resistant polyurethane sections joined together with quick-release stainless steel clamps. Depending on wear, each section can be replaced quickly and easily.

**Extends equipment life.** The D-SANDER hydrocyclone helps minimize maintenance, repair and replacement of downstream equipment. Field test data confirms that an M-I SWACO D-SANDER unit increases the life of mud-pump-fluid end parts by 300 to 400% and minimizes downtime.

**Reduces operating costs.** Based on actual comparative field tests, operators using the M-I SWACO D-SANDER hydrocyclone could increase bit performance by 20% and reduce overall drilling time by 23%.

**Rugged construction.** Built for the oilfield, the D-SANDER hydrocyclone provides reliable, long in-service life.



### D-SANDER Unit Minimizes Sand-Related Problems

The M-I SWACO D-SANDER hydrocyclone can take suction from the actual mud-return system as soon as it passes through the shale shaker or leaves the flow line. Ideally, the front end of the first mud tank is partitioned with an overflow gate.

The D-SANDER unit then takes the suction from the first half of the tank, removes the sand and abrasive cuttings, and returns the clean mud to the second half of the first tank. With this arrangement, virtually no sand can settle in the tank.

The D-SANDER hydrocyclone can efficiently function to handle any combination of rig pump and sand conditions. The 12-in. (304.8-mm) clone D-SANDER unit reduces the sand content to a trace in normal drilling fluids. The compounded polyurethane clones are extremely durable with long in-service life expectancy. The clones are designed to deliver outstanding wear resistance — up to three times the service life of conventional rubber-lined, metal units.

The clones are cast in four polyurethane sections to counteract uneven wear characteristics caused by sand, abrasive cuttings and flow — in the feed unit, the return unit, the tapered hydrocyclone section and the discard port. Each section is joined together by stainless steel, quick-release clamps. This makes handling, installation and maintenance easier and minimizes downtime.

The inlet or feed section is designed to reduce potential turbulence when channeling the slurry into the cone and prevent it from mixing back into the incoming feed. The specially tapered cone separates the fines and fluids from the sand and cuttings, delivering them to the return outlet and discarding the sand and cuttings through the outlet port.

The result is a D-SANDER hydrocyclone that is more efficient, can process more sand at the same operating pressure or can process the same amount of sand at a reduced pressure.

### Specifications

Model	Number of Clones	Length in. (mm)	Width in. (mm)	Height in. (mm)	Weight lb (kg)	Capacity gpm (L/min)
1-12 D-SANDER (vertical)	1	33 (838.2)	19.5 (495.3)	73.81 (1,874.9)	400 (181)	500 (1,892.7)
2-12 D-SANDER (vertical)	2	36.12 (917.6)	62 (1,574.9)	71.5 (1,817.8)	1,036 (470)	1,000 (3,785.4)
2-12 D-SANDER (slant)	2	78 (1,981.2)	52 (1,320.8)	35.5 (901.3)	1,008 (457)	1,000 (3,785.4)
3-12 D-SANDER (vertical)	3	47.7 (1,212)	69.6 (1,768)	88.0 (2,235)	2,250 (1,020)	1,500 (5,678.1)
3-12 D-SANDER (slant)	3	79.5 (2,019)	74.56 (1,894)	45.5 (1,156)	1,816 (824)	1,500 (5,678.1)

**Engineering Drawing: 2-12 Vertical-Mount D-SANDER**

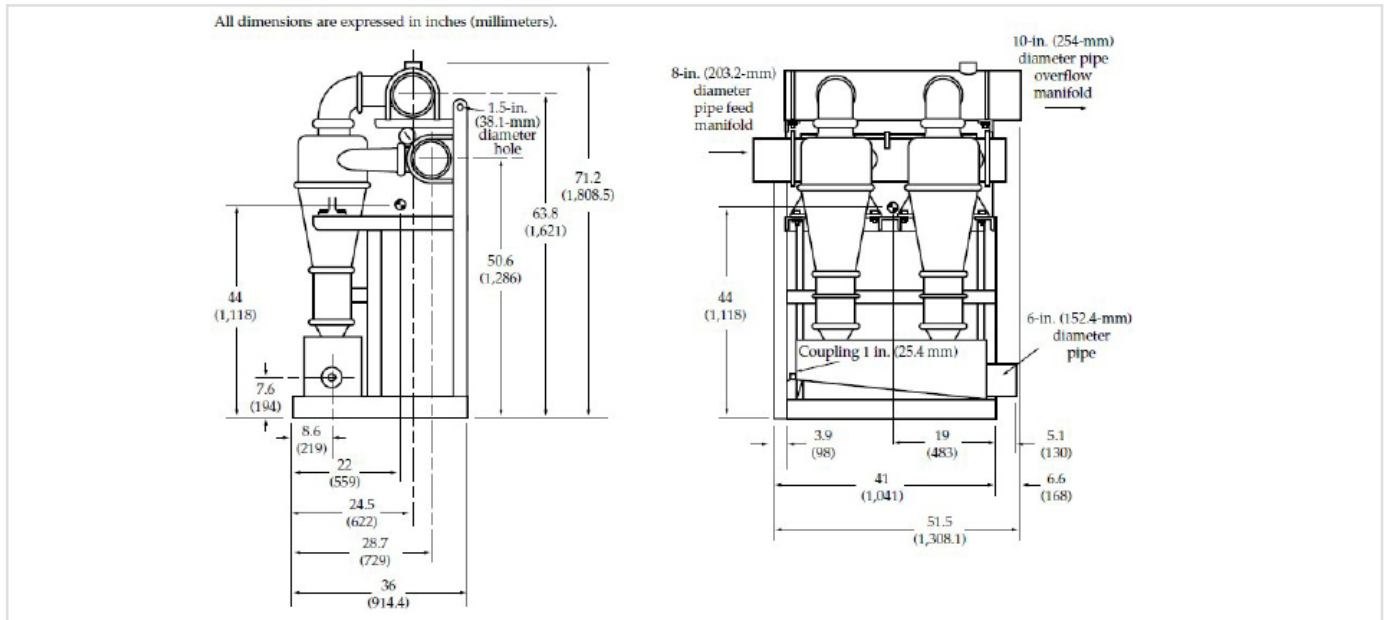

**Engineering Drawing: 3-12 Vertical-Mount D-SANDER**

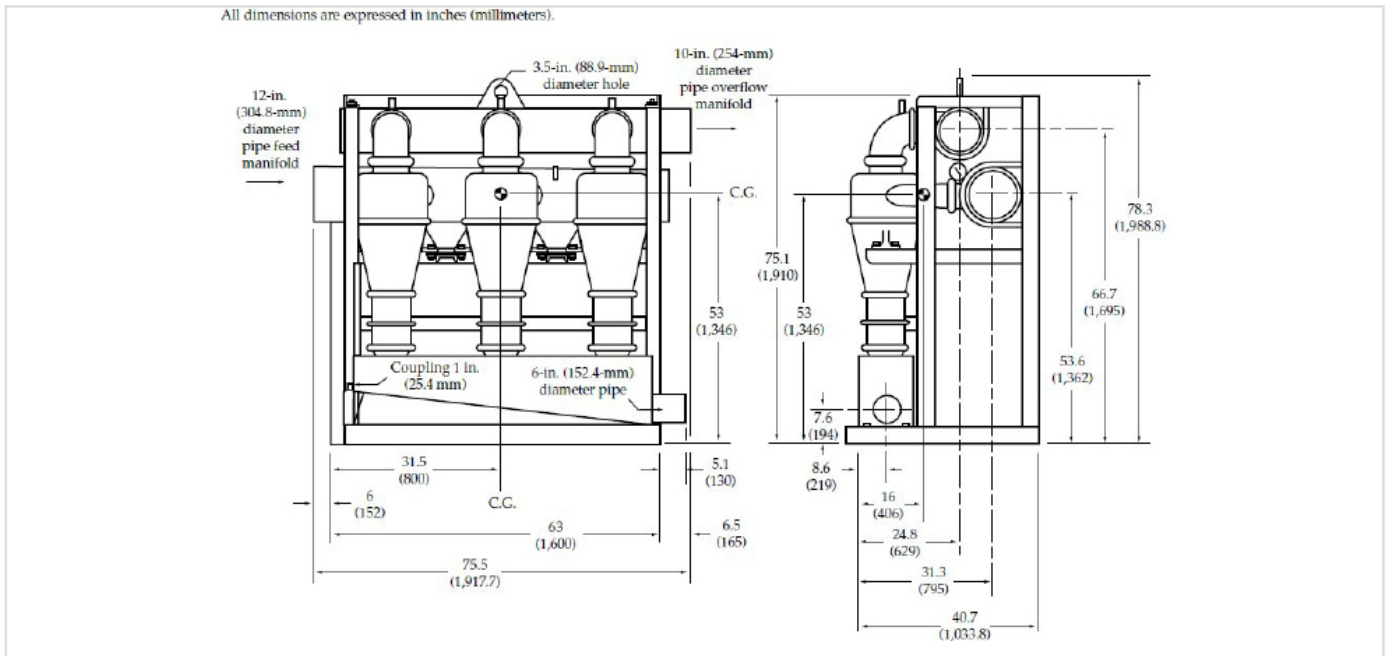

**Engineering Drawing: 2-12 Slant-Mount D-SANDER**

All dimensions are expressed in inches (millimeters).

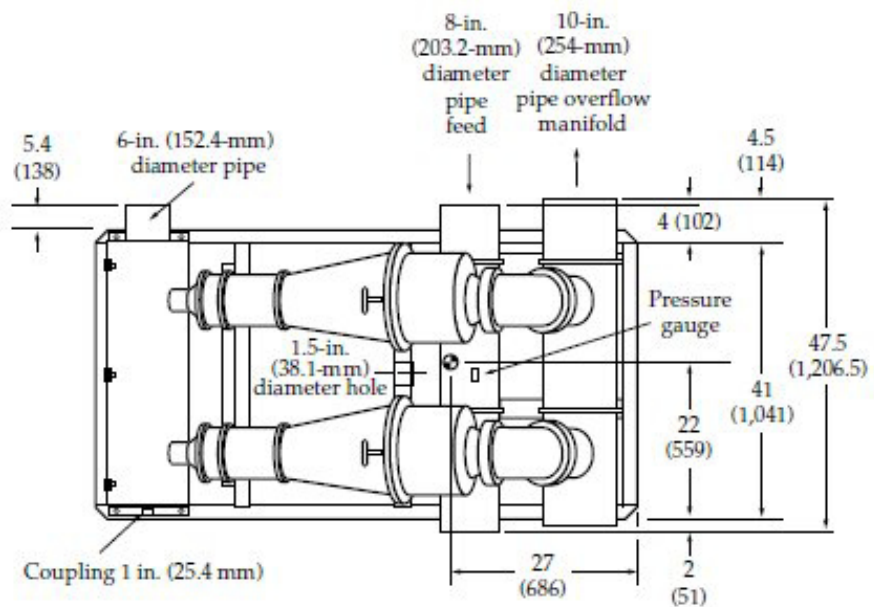
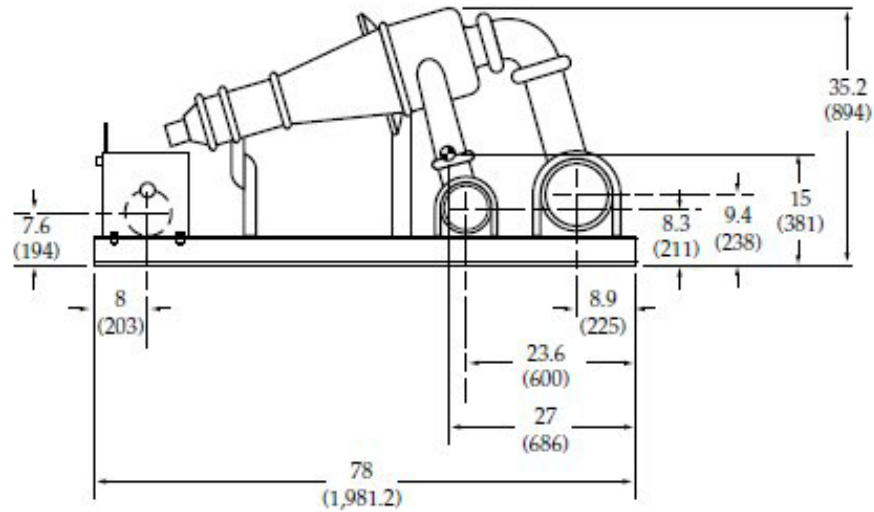

## Engineering Drawing: 3-12 Slant-Mount D-SANDER

All dimensions are expressed in inches (millimeters).

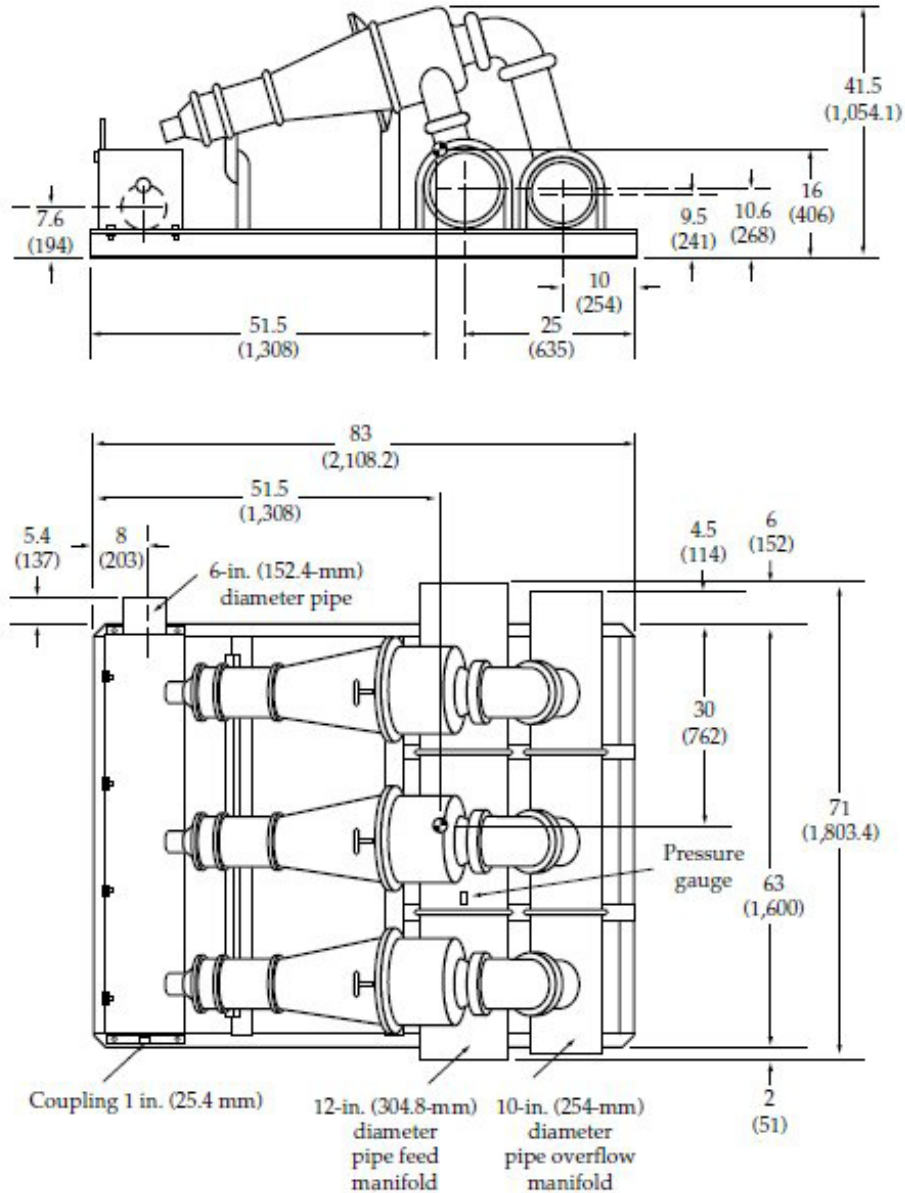

**Mi SWACO**  
A Schlumberger Company

P.O. Box 42842  
Houston, Texas 77242-2842  
Tel: 281-988-1866  
1-800-654-0660  
Fax: 281-988-1888  
www.miswaco.com  
E-mail: questions@miswaco.com

This information is supplied solely for informational purposes and M-I SWACO makes no guarantees or warranties, either expressed or implied, with respect to the accuracy and use of this data. All product warranties and guarantees shall be governed by the Standard Terms of Sale.